

PALETTI

PRECISE, FLEXIBLE, DURABLE

CONVEYOR TECHNOLOGY – CUSTOMIZED FROM OUR MODULAR SYSTEMS

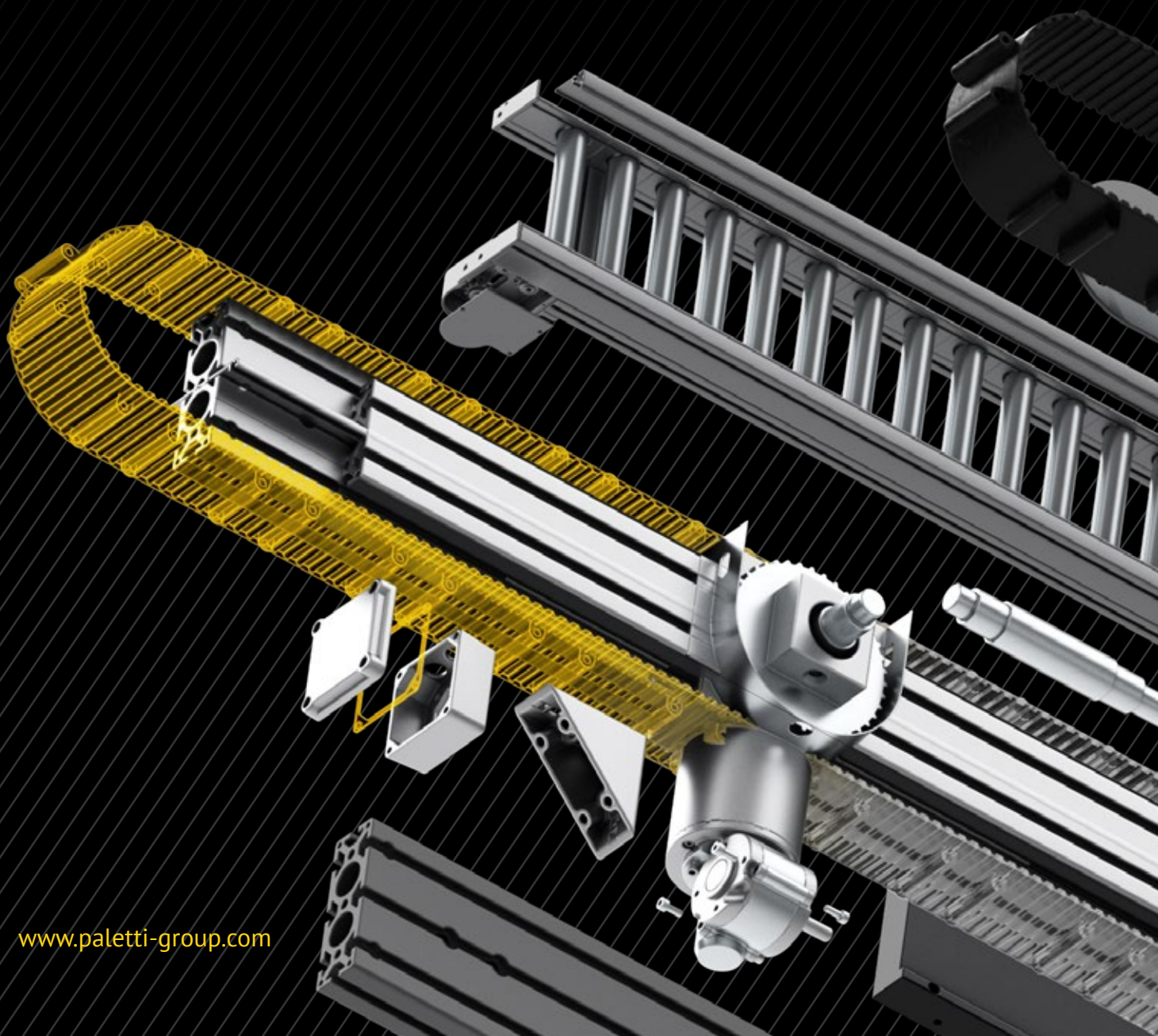

www.paletti-group.com

NON-STOP MOVEMENT

FLAT BELT CONVEYOR

Our belt and timing belt conveyors, designed from Paletti's extensive modular construction kit, offer the right solution for all applications! From standard systems to individual customer solutions, we are the right partner for extra service. Because we ensure efficient transport processes and at the same time offer maximum flexibility, safety and reliability.

From the standardized modular system to the individual solution. It's all plain sailing.



Belt conveyors are used to transport packaged and unpackaged unit loads and are suitable for a wide range of formats and weights. Thanks to their adaptability, belt conveyors are often the ideal choice as transport aids for machines, especially for infeed and outfeed.

Our standardized and modular belt conveyors, which are manufactured on the basis of our 40x40 semi profile system, have a length of up to 6 meters and enable simple transport tasks up to a load of 50 kg/m.

Standard widths	400 / 600 / 800
Conveyor lengths	up to 4 m, optionally up to 6 m with reduced load
Construction	profile 40x40 semi, sheet steel to support the belt
Max. permitted belt weight	50 kg/m
Speed	from 3 m/min to 50 m/min
Designed for SEW motors	hollow shafts 16 / 20 mm
Drive	Head drive left or right in position 0° / 90° / 180°, centre drive alternatively possible
Belt	PVC - green, other belts on request
Railing	Modular railing, alternatively folded sheet steel (side upstand min. 10 mm)
Special design	with reduced deflection diameter (knife edge) possible

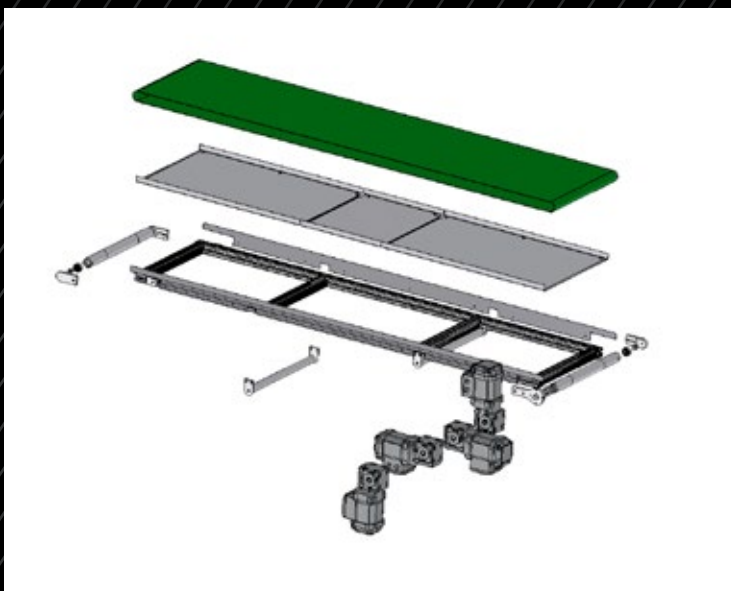

MOUNTING THE DRIVE



Direct head drive



Indirect head drive



Direct center drive

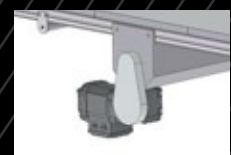

Indirect center drive

TRANSPORT SOLUTIONS THAT MOVE

TOOTHED TIMING BELT CONVEYOR

Timing belt conveyors are usually used to transport intermittent and dimensionally stable piece goods or workpiece carriers. Thanks to the different drive variants and the option of combining several tracks, they are the ideal transport aids for complex inter-linking solutions or for the infeed and outfeed of machines for longer piece goods or workpieces.

Our standard systems are designed as double-track systems and can be customised at any time.

The special feature of our modular system is the smallest possible design, as space within a machine is often very limited.

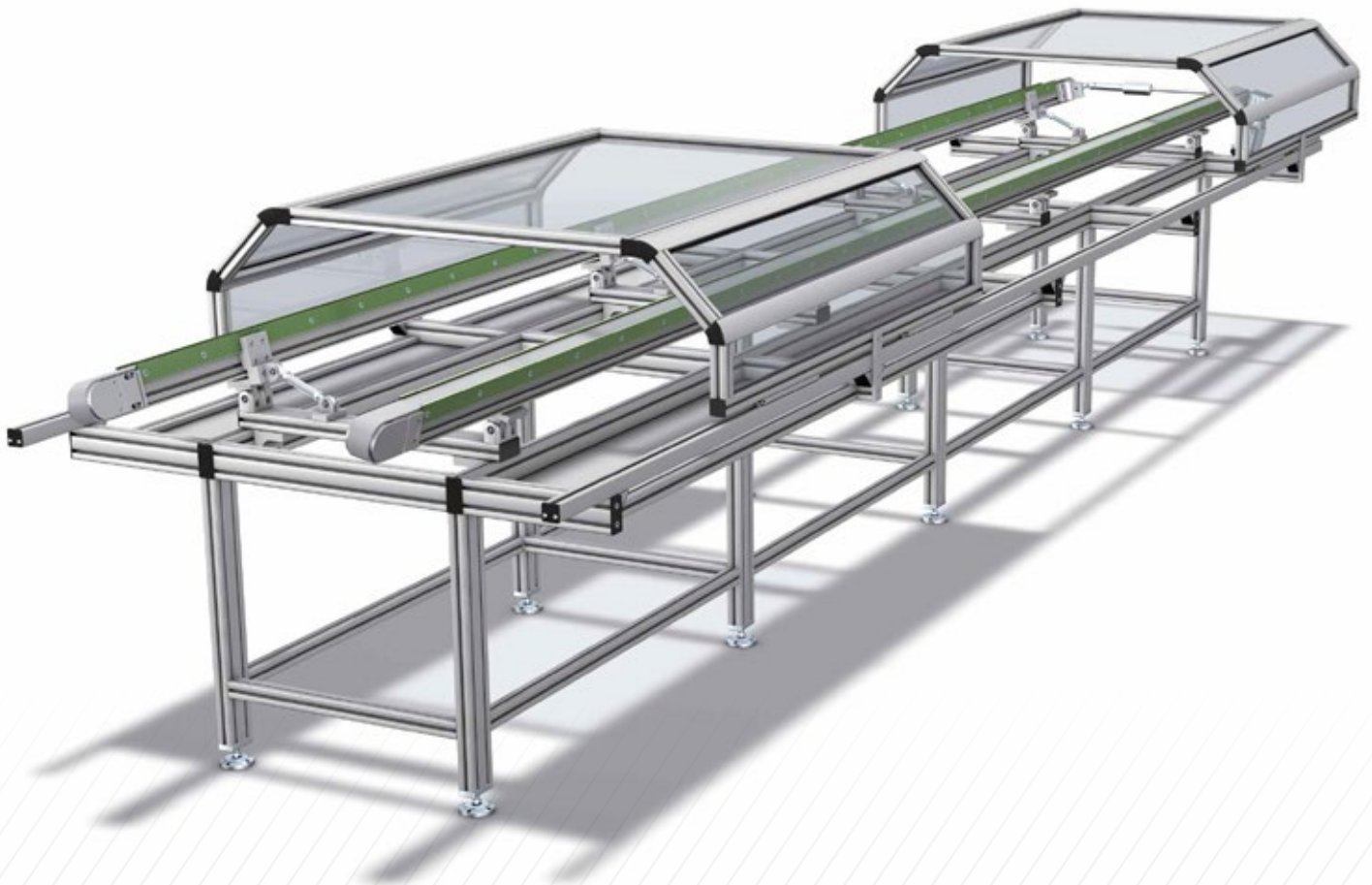

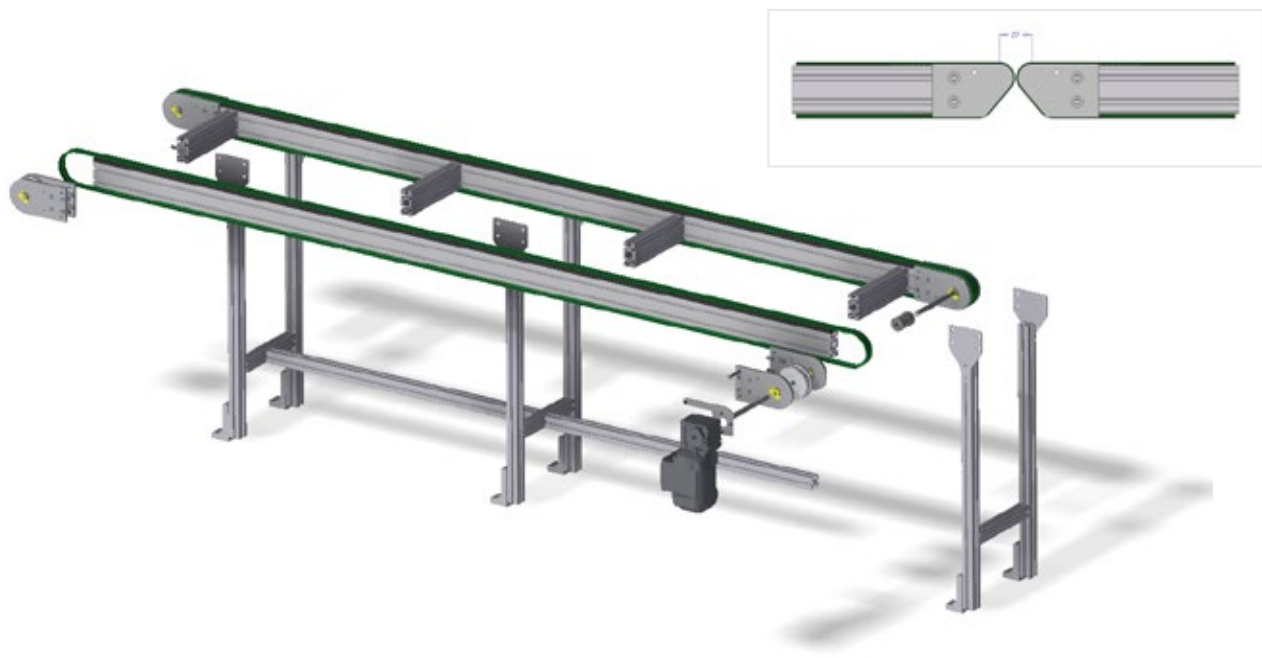

	HEAVY	MEDIUM	LIGHT
Standard widths	400 / 600 / 800 / 1000		100 / 200 / 300
Conveyor lengths	up to 4 m, optionally up to 6 m		up to 2 m
Construction	Profile 40 x 80 semi	Profile 30 x 60 midi	Profile 20 x 40 mini
max. belt weight	50 kg/m	40 kg/m	10 kg/m
Speed	3m/min - 50 m/min		3 m/min - 50 m/min
Pre-aligned Motors	SEW - Hollow shafts 16 / 20 / 40 mm		Max. Motor - hollow shafts 16 / 20
Drive	Head drive - left or right - position 0° / 90° / 180° Center drive possible		Center drive - 0° position
Toothed belt	Width 32 mm - AT10	Width 25 mm - AT 10	Width 16 mm - AT 5
Railing	Modular system possible		According to customer requirements
Special version	Reduced deflection diameter (knife edge) possible		
Substructure	Modular system possible		Individual

SUBSTRUCTURE FOR BELT CONVEYORS AND TIMING BELT CONVEYORS

- ▶ **H-shaped substructure supports for standard widths:** 400 / 600 / 800 / 1000
- ▶ **Standard height of the substructure supports:** 950 mm
- ▶ **Connecting strut:** Length max. 1500 mm
- ▶ **Construction:** Profile 40 x 40 semi, connecting plates AL 160 x 160
- ▶ **Floor connection:** Angled feet, optionally height-adjustable or with castors Ø 125 mm

FOR SMOOTH TRANSPORTATION

CHAIN CONVEYOR

Wherever belt or roller conveyors cannot be used due to the transport task, Paletti relies on link chain conveyors for automation solutions. These robust, low-noise and durable systems are primarily used in the automotive industry, the food industry, the pharmaceutical industry, the consumer goods industry, intralogistics and e-commerce. The modular design in length, width and height as well as the quick replacement in the event of damage ensure cost-effective use for the transport of a wide variety of unit loads. Efficient and versatile transport systems for greater productivity in material transport.

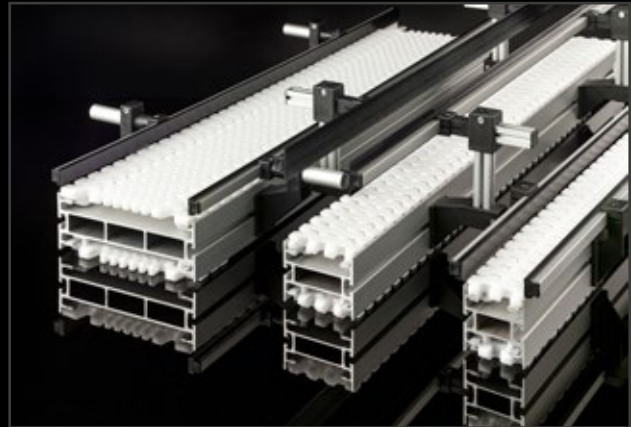

Chain conveyor STRETCH_LINE 065

- ▶ Total width 65 mm
- ▶ Chain width 62 mm
- ▶ Product width 15-140 mm
- ▶ Max. Belt speed: 80 m/min
- ▶ Max. Belt length: 30 m
- ▶ Max. Product weight: 10 kg



Chain conveyor STRETCH_LINE 090 / CLOSED

- ▶ Total width 90 mm
- ▶ Chain width 87 mm
- ▶ Product width 20-200 mm
- ▶ Max. Belt speed: 80 m/min
- ▶ Max. Belt length: 30 m
- ▶ Max. Product weight: 10 kg

Also available in the CLOSED version without groove in the chain guide profile.



Chain conveyor STRETCH_LINE 200

- ▶ Total width: 200 mm
- ▶ Chain width: 194 mm
- ▶ Product width: 100-400 mm
- ▶ Max. Belt speed: 60 m/min
- ▶ Max. Belt length: 30 m
- ▶ Max. Product weight: 15 kg

GANZ VON DER ROLLE

ROLLER CONVEYOR

Paletti manufactures a special profile for driven roller conveyors, which consists of four individual profiles that are joined together using clip technology to form a complete roller conveyor profile. This enables easy assembly and disassembly in the installed state. For non-driven

conveyors, any conveying or transportation task can be fulfilled by combining a wide range of Paletti standard profiles 40 with some additional systems such as pneumatic pushers, stoppers, etc.



Driven roller conveyors standard



Non-driven roller conveyors standard

THE PERFECT SOLUTION

WORKPIECE CARRIER

The perfect WorkPiece Carrier curve conveyor system for the automated handling of products.

The FS-CS090SL.WPC workpiece carrier system is the answer to transporting workpiece carriers with products from numerous industries, such as the automotive industry or the electrical and electronics industry. FS-CS090SL.WPC is particularly suitable for interlinking machines and manual workstations as well as for feeding parts in automated manufacturing and assembly processes.

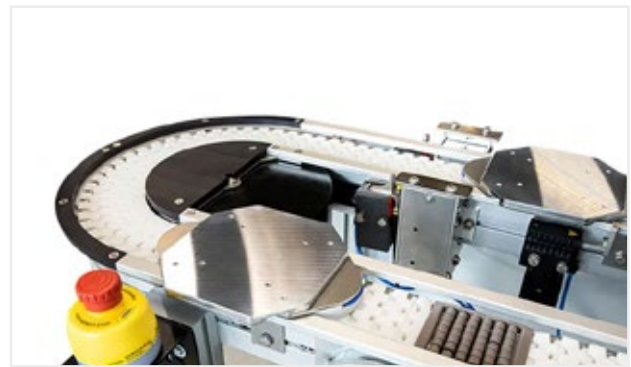

In addition to the FS-CS090SL.ALU components, such as conveyor profile, conveyor chain, drives, horizontal curves with disk, the system is supplemented by the use of:

- ▶ Workpiece carriers
- ▶ Railing components
- ▶ Lifting/positioning unit
- ▶ Stopper
- ▶ Sensors
- ▶ Identification system (RFID)

Conveyor belt:

- ▶ Max. Conveyor weight: 150 kg
- ▶ Max. Belt length: 20 m
- ▶ Max. Belt speed: 30 m/min
- ▶ Various drive options
- ▶ WorkPiece Carrier (WPC):
 - ▶ Usable width: 150 mm
 - ▶ Max. Product weight: 10 kg

PALETTI

EVERYTHING HAS ITS PLACE

ENGINEERED SYSTEM SOLUTIONS



PROFILE TECHNOLOGY



PROTECTION AND SEPARATION SYSTEMS



ASSEMBLY AND WORKSTATION SYSTEMS



CONVEYOR TECHNOLOGY



LINEAR TECHNOLOGY



TEST BENCH TECHNOLOGY



LASER SAFETY ENCLOSURES



PRECISION ENGINEERING

Paletti Profilsysteme GmbH & Co. KG

Gewerbepark Meißen 17
D-32423 Minden
Phone +49 (571) 38 73 03-0
sales@paletti-group.com
www.paletti-group.com

